

AMRE

Electric motors and hydraulic electropumps since 1954
More than 1200 different models from 200W to 50 kW
Motors projected on customer specifications

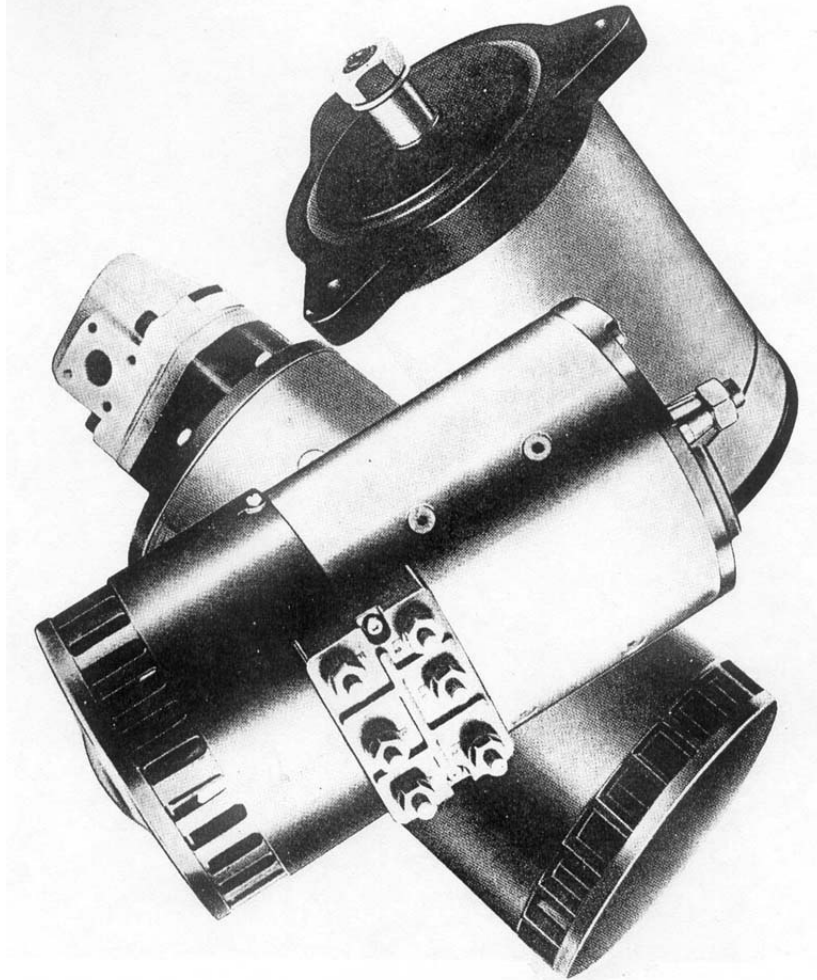

- ✓ **Motors with series, shunt, compound excitation**
2-3-4-5-6 clamps
- ✓ **Motors with separate excitation 24-48-80V**
- ✓ **Motors with auxiliary poles (4 + 4 poles)**
- ✓ **Motors with field weakening predisposition**
- ✓ **Armatures with compensation circuit**
- ✓ **Excellent motors for energy recovery**

AMRE

MAIN APPLICATION OF OUR MOTORS

PLATFORM TRANSPORTER

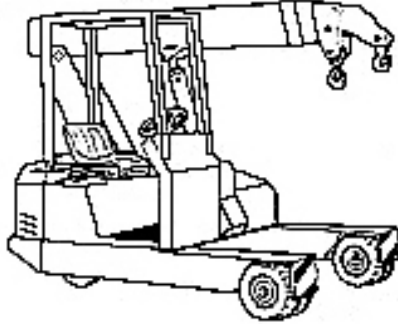

ELETTRIC CRANES



AIRPORT TRACTORS

TRACTION MOTORS

*Lifting electropumps
Hidraulic and mechanical
Steering motors*

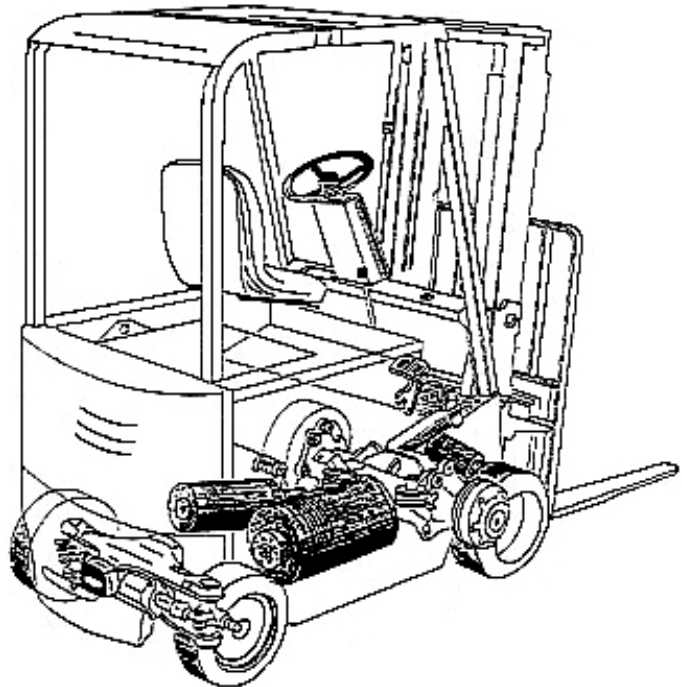

*MOTORS FOR GOLF CARS
VEHICLES AND ROUNDABOUT
FOR FUN-FAIRS
MINING VEHICLE*

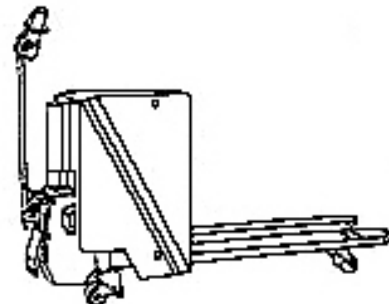

MOTORS FOR MOTORWHEELS

MAIN APPLICATION OF OUR MOTORS

WASHING MACHINE

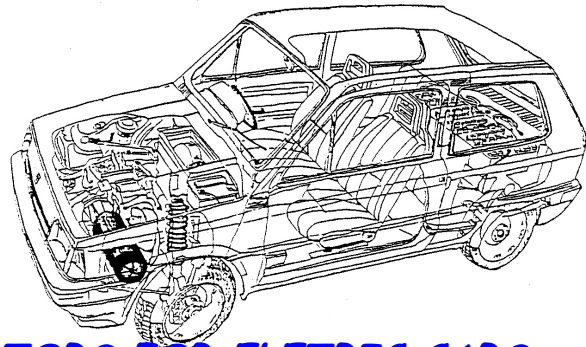
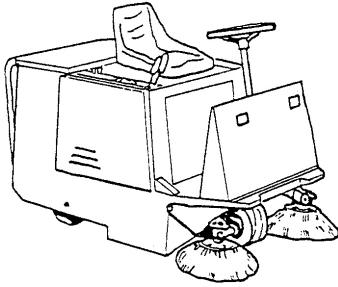

MOTORS FOR ELETRIC CARS

MOTORS FOR MECHANICAL WINDLASS



MOTORS FOR SEA AMBIENT USE

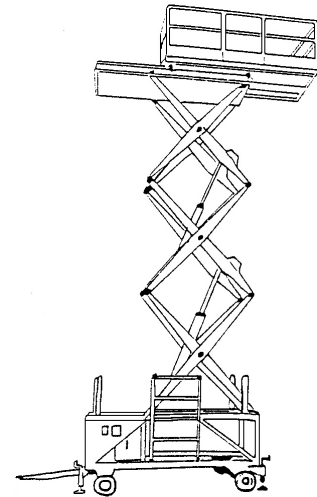
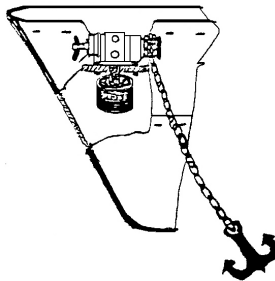

ELECTROPUMPS FOR ACCES PLATFORMS TELESCOPIC ARMS

ELECTROPUMPS FOR TRUCK HIDRAULIC SYSTEMS

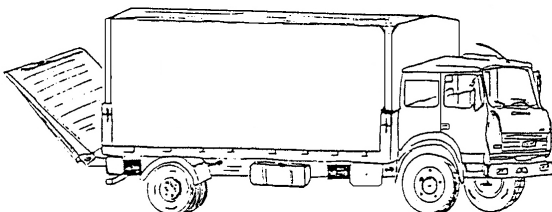

M.I.L. STANDARD MOTORS

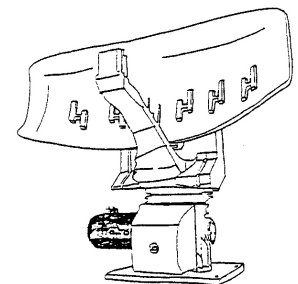

AMRE

OUR OPTIONS:

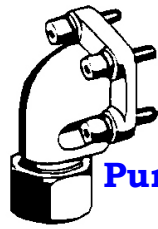

**Pump Connection
Flanges**

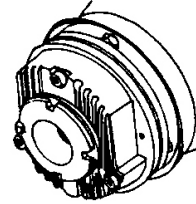

Electromagnetic Brakes

Fixing Feet With Grooved Vibration-Damping Device

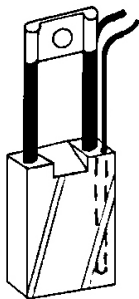
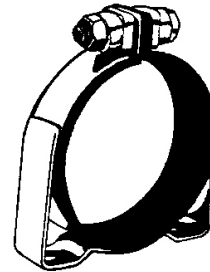
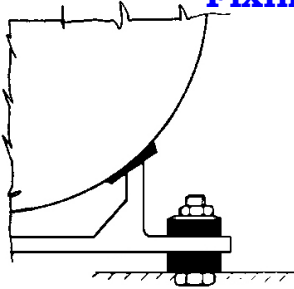

**Brush Wear
Indicators**

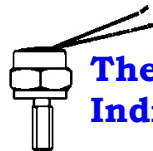

**Thermic Alarm
Indicators**

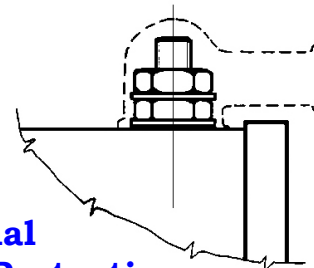

**Terminal
Protections**

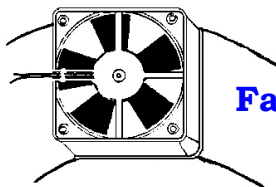

**Fan For
Forced Airy**

AMRE



GENERAL CATALOGUE

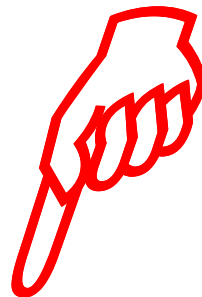

D.C. TRACTION MOTORS

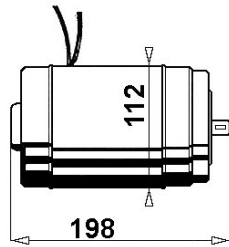

- MOTOR 200 W 12 - 24 VOLT 2000 RPM
- MOTOR 350 W 12 - 24 VOLT 2800 RPM
- MOTOR 350 W 36 - 48 VOLT 2800 RPM

PERMANENT MAGNET MOTORS

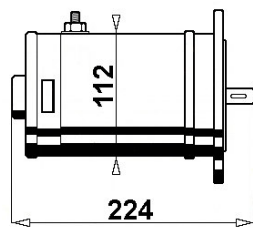

- MOTOR 350 W 12 - 24 VOLT 1300 RPM
- MOTOR 700 W 12 - 24 VOLT 2800 RPM
- MOTOR 700 W 24 VOLT 1700 RPM
- MOTOR 1000 W 12 - 24 VOLT 2900 RPM

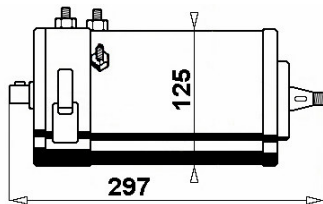

- MOTOR 500 W 24 VOLT 1000 RPM
- MOTOR 500 W 24 VOLT 1670 RPM
- MOTOR 700 W 24 VOLT 1800 RPM
- MOTOR 700 W 24 VOLT 2300 RPM

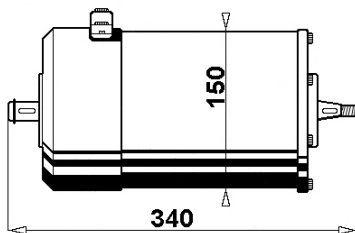

- MOTOR 1000 W 24 - 48 VOLT 1500 RPM
- MOTOR 1500 W 24 - 48 VOLT 1850 RPM
- MOTOR 2000 W 24 - 48 VOLT 1800 RPM
- MOTOR 2000 W 36 - 40 VOLT 1800 RPM

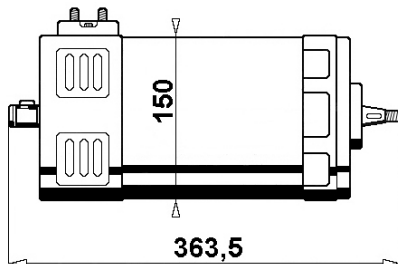

- MOTOR 1000 W 24 - 48 VOLT 1500 RPM
- MOTOR 1500 W 24 - 48 VOLT 2250 RPM
- MOTOR 2000 W 24 - 48 VOLT 2250 RPM
- MOTOR 2600 W 24 - 48 VOLT 2250 RPM

D.C. TRACTION MOTORS

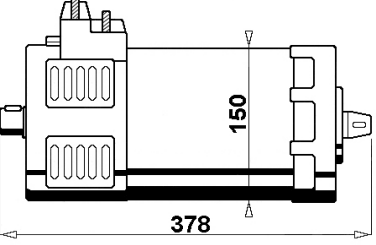
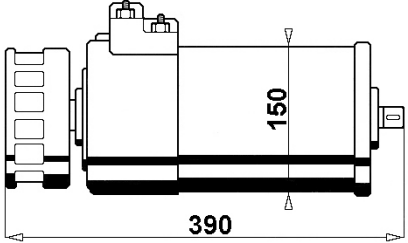
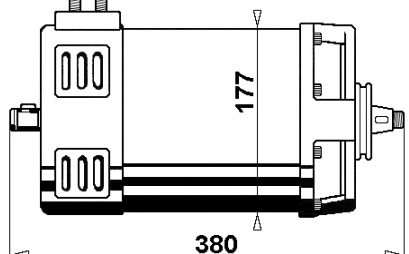
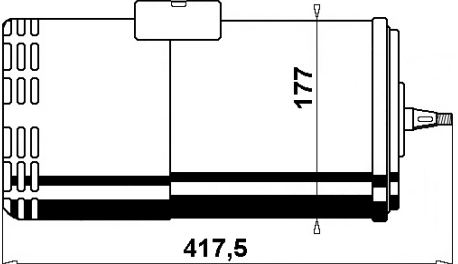
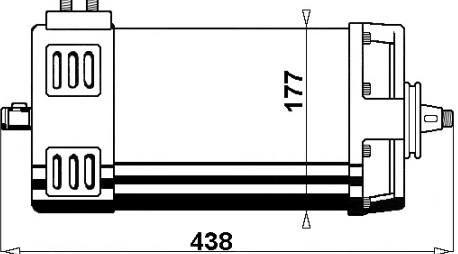
	<ul style="list-style-type: none"> - MOTOR 3000 W 24 VOLT 1800 RPM - MOTOR 3000 W 24 VOLT 2800 RPM - MOTOR 3500 W 24 VOLT 2380 RPM - MOTOR 3500 W 40 - 48 VOLT 2630 RPM
	<ul style="list-style-type: none"> - MOTOR 3000 W 24 VOLT 2800 RPM - MOTOR 3500 W 24 VOLT 2380 RPM - MOTOR 3500 W 48 VOLT 2630 RPM
	<ul style="list-style-type: none"> - MOTOR 3200 W 24 VOLT 2100 RPM - MOTOR 3800 W 48 VOLT 2050 RPM - MOTOR 4000 W 40 - 48 VOLT 2230 RPM - MOTOR 4400 W 48 VOLT 2100 RPM
	<ul style="list-style-type: none"> - MOTOR 2500 W 48 VOLT 1420 - 2000 RPM - MOTOR 5000 W 36 - 40 VOLT 2500 - 3100 RPM - MOTOR 5000 W 72 - 80 VOLT 2160 - 3100 RPM
	<ul style="list-style-type: none"> - MOTOR 3000 W 24 VOLT 1600 RPM - MOTOR 5000 W 36 - 40 VOLT 1600 RPM - MOTOR 5000 W 48 VOLT 2500 RPM - MOTOR 5000 W 80 VOLT 2000 RPM

D.C. TRACTION MOTORS

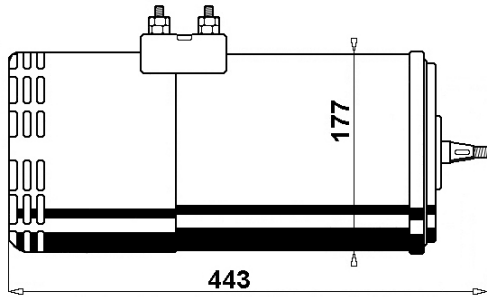

- MOTOR 3000 W 24 VOLT 1020 – 1600 RPM
- MOTOR 3500 W 48 VOLT 1200 – 1600 RPM
- MOTOR 5000 W 36 - 48 VOLT 2500 – 3100 RPM
- MOTOR 5000 W 72 - 80 VOLT 2100 – 3100 RPM

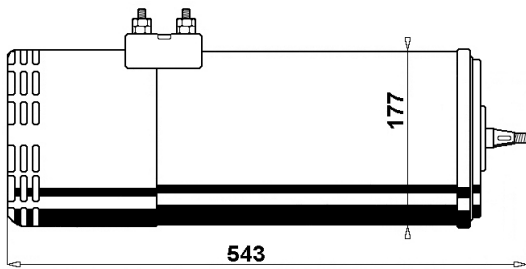

- MOTOR 5000 W 48 VOLT 1350 – 1850 RPM
- MOTOR 6000 W 40 VOLT 2000 RPM
- MOTOR 8000 W 48 VOLT 2500 – 3300 RPM
- MOTOR 8000 W 72 - 80 VOLT 2500 – 3100 RPM
- MOTOR 10000 W 80 VOLT 2000 RPM

FORCED VENTILATION

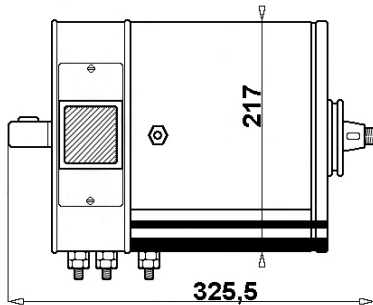

- MOTOR 3000 W 24 VOLT 2000 RPM
- MOTOR 4300 W 48 VOLT 2300 RPM
- MOTOR 6000 W 80 VOLT 2800 RPM

FOR HURT GEARBOX HFS 50 – 500

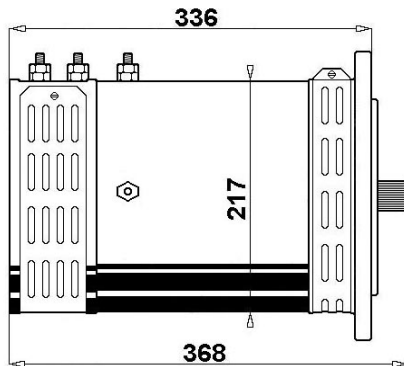

- MOTOR 4000 W 24 VOLT 1400 RPM
- MOTOR 5000 W 36 VOLT 1700 RPM
- MOTOR 6000 W 48 VOLT 1950 RPM
- MOTOR 6000 W 80 VOLT 2000 RPM

D.C. TRACTION MOTORS

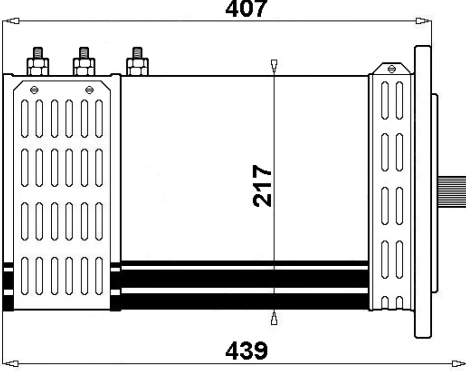
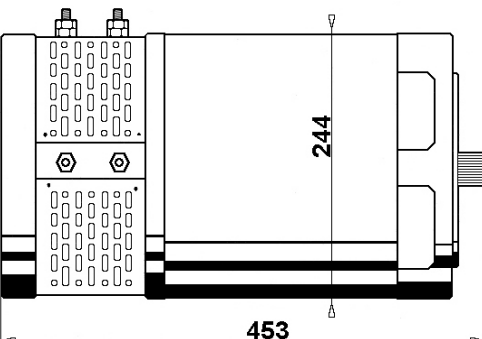
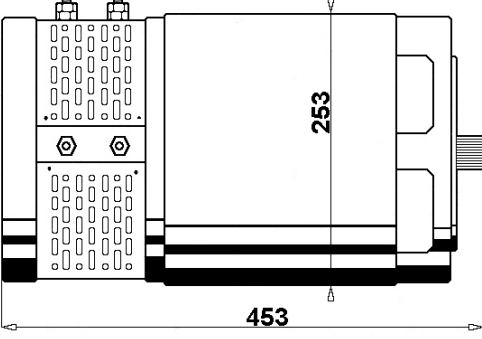
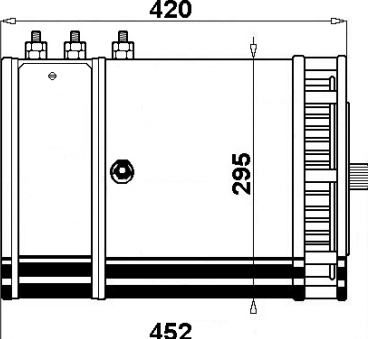
	<ul style="list-style-type: none"> -MOTOR 6000 W 36 - 40 VOLT 1650 RPM -MOTOR 6800 W 48 VOLT 1650 RPM -MOTOR 8500 W 80 VOLT 2800 RPM
	<ul style="list-style-type: none"> -MOTOR 5000 W 48 VOLT 1100 RPM -MOTOR 8000 W 48 VOLT 1080 - 1400 RPM -MOTOR 8000 W 72 - 80 VOLT 2000 RPM -MOTOR 10000 W 80 VOLT 1950 RPM
	<ul style="list-style-type: none"> -MOTOR 8000 W 48 VOLT 940 - 1170 RPM -MOTOR 8000 W 48 VOLT 1300 RPM -MOTOR 9000 W 72 VOLT 1620 RPM -MOTOR 10000 W 80 VOLT 1860 - 2500 RPM
	<ul style="list-style-type: none"> -MOTOR 8000 W 48 VOLT 1230 RPM -MOTOR 10000 W 72 - 80 VOLT 1650 RPM -MOTOR 13000 W 72 - 80 VOLT 2250 RPM -MOTOR 15000 W 80 VOLT 1700 RPM

D.C. TRACTION MOTORS

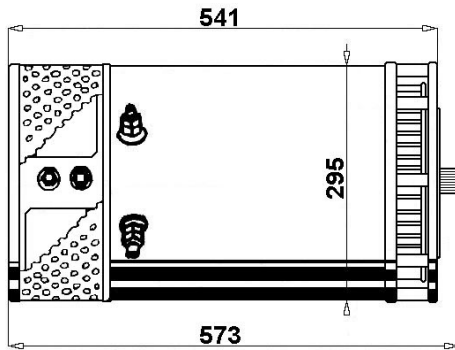

- MOTOR 15000 W 72 VOLT 2000 RPM
- MOTOR 15000 W 80 VOLT 1300 RPM
- MOTOR 15000 W 80 VOLT 1800 RPM
- MOTOR 17000 W 80 VOLT 2100 RPM

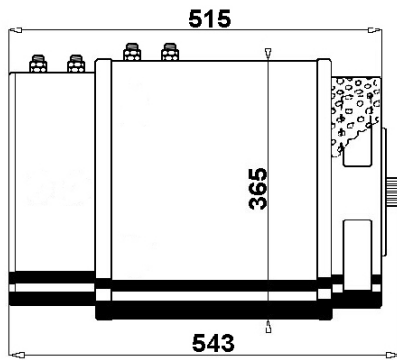

- MOTOR 18000 W 80 VOLT 1500 RPM
- MOTOR 20000 W 72 - 80 VOLT 1150 RPM
- MOTOR 21000 W 80 - 96 VOLT 1150 RPM

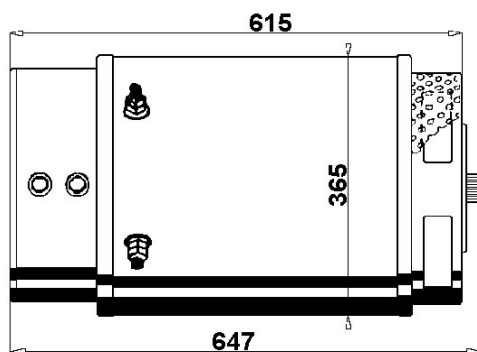

- MOTOR 20000 W 80 VOLT 1250 RPM
- MOTOR 24000 W 80 VOLT 1200 RPM
- MOTOR 25000 W 72 VOLT 1150 RPM
- MOTOR 27000 W 80 VOLT 1150 RPM
- MOTOR 30000 W 80 VOLT 1380 RPM
- MOTOR 36000 W 96 VOLT 1650 RPM

MOTORS FOR HURTH-KORDEL

TECNOSTILE-PROMEC GEARBOXES

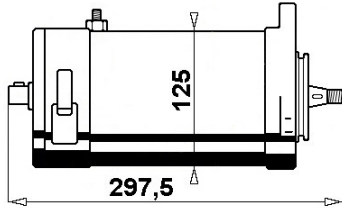

- MOTOR 500 W 24 VOLT 1000 RPM 4 TERM
- MOTOR 500 W 24 VOLT 1670 RPM 3 TERM
- MOTOR 700 W 24 VOLT 1800 RPM 3 TERM
- MOTOR 700 W 24 VOLT 2300 RPM 3 TERM

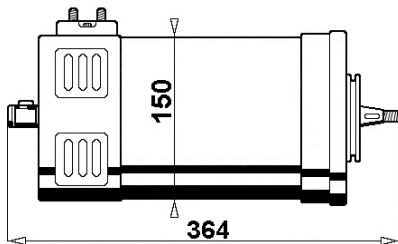

- MOTOR 1000 W 24 VOLT 1500 RPM 3 TERM
- MOTOR 1500 W 24 VOLT 1850 RPM 3 TERM
- MOTOR 2000 W 24 - 48 VOLT 2250 RPM 3 TERM
- MOTOR 2600 W 24 - 48 VOLT 2250 RPM 4 TERM

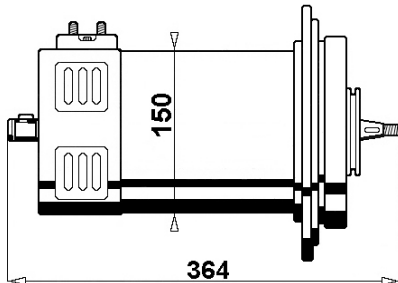

- MOTOR 1000 W 24 VOLT 1500 RPM 3 TERM
- MOTOR 1500 W 24 VOLT 1850 RPM 3 TERM
- MOTOR 2000 W 24 - 48 VOLT 2250 RPM 3 TERM
- MOTOR 2600 W 24 - 48 VOLT 2250 RPM 4 TERM

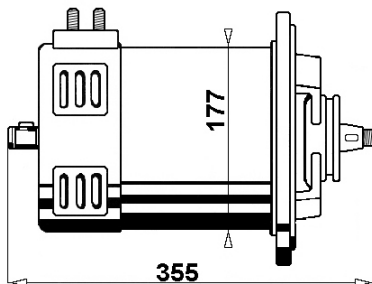

- MOTOR 3200 W 24 VOLT 2100 RPM 4 TERM
- MOTOR 3200 W 40 - 48 VOLT 2100 RPM 4 TERM

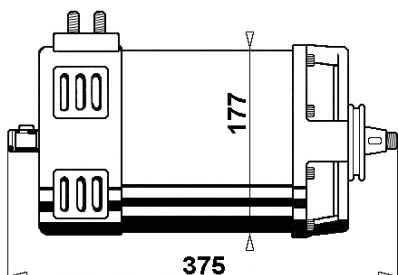

- MOTOR 3800 W 40 - 48 VOLT 2050 RPM 4 TERM
- MOTOR 4000 W 40 - 48 VOLT 2230 RPM 4 TERM
- MOTOR 4400 W 40 - 48 VOLT 2100 RPM 4 TERM

MOTORS FOR HURTH-KORDEL

TECNOSTILE-PROMEC GEARBOXES

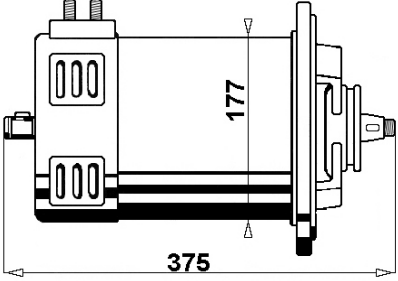
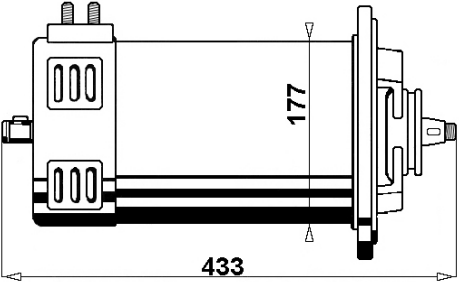
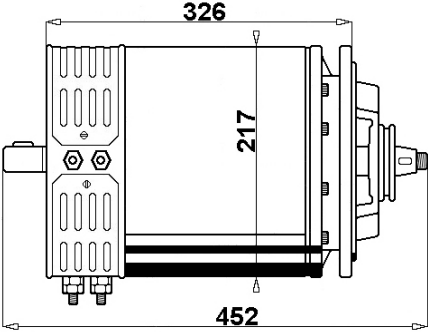
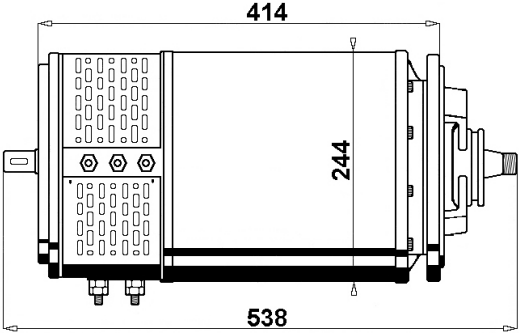
	<p>-MOTOR 4000 W 40 - 48 VOLT 2230 RPM 4 TERM</p> <p>-MOTOR 5000 W 48 VOLT 2350 RPM 4 TERM</p>
	<p>-MOTOR 3000 W 24 VOLT 2100 RPM 6 TERM</p> <p>-MOTOR 5000 W 40 - 48 VOLT 2500 RPM 4 TERM</p> <p>-MOTOR 5000 W 48 VOLT 3500 RPM 4 TERM</p> <p>-MOTOR 5000 W 72 - 80 VOLT 2000 RPM 4 TERM</p>
	<p>-MOTOR 6000 W 40 - 48 VOLT 1950 RPM 4 TERM</p> <p>-MOTOR 6000 W 72 - 80 VOLT 2000 RPM 4 TERM</p>
	<p>-MOTOR 8000 W 48 VOLT 1280 RPM 5 TERM</p> <p>-MOTOR 8000 W 72 - 80 VOLT 2000 RPM 4 TERM</p>

D.C. OIL HIDRAULIC ELECTROPUMPS

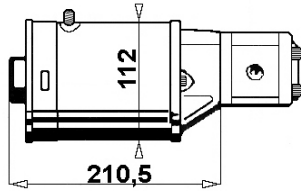

- ELP. 1500 W 12 VOLT 1800 RPM
- ELP. 2000 W 24 VOLT 2000 RPM
- ELP. 2000 W 40 VOLT 2000 RPM
- ELP. 2000 W 48 VOLT 2200 RPM

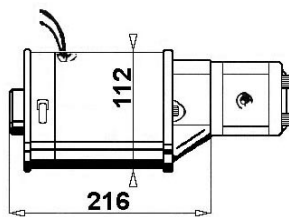

- ELP. 500 W 12 VOLT 2000 RPM
- ELP. 500 W 24 VOLT 2000 RPM
- ELP. 500 W 40 - 48 VOLT 2000 RPM

PERMANENT MAGNETS

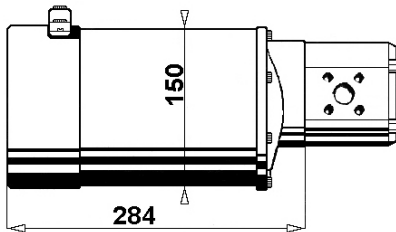

- ELP. 2500 W 24 VOLT 1620 RPM
- ELP. 2500 W 36 VOLT 1450 RPM
- ELP. 2500 W 40 VOLT 1620 RPM
- ELP. 2500 W 48 VOLT 2000 RPM
- ELP. 2500 W 72 VOLT 1800 RPM
- ELP. 2500 W 80 VOLT 2000 RPM

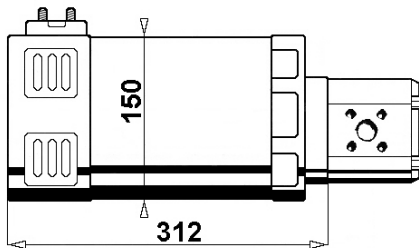

- ELP. 3000 W 24 VOLT 1500 RPM
- ELP. 3000 W 48 VOLT 1800 RPM
- ELP. 3000 W 80 VOLT 1750 RPM

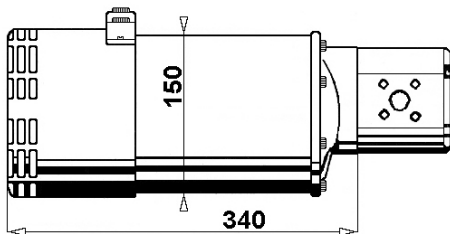

- ELP. 3000 W 24 VOLT 1500 RPM
- ELP. 3000 W 48 VOLT 1800 RPM
- ELP. 3000 W 80 VOLT 1750 RPM

D.C. OIL HIDRAULIC ELECTROPUMPS

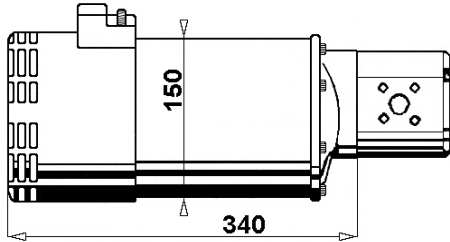

-ELP. 2500 W	12 VOLT	1100 RPM
-ELP. 4000 W	24 VOLT	1800 – 2450 RPM
-ELP. 4000 W	48 VOLT	1400 RPM
-ELP. 4500 W	36 VOLT	2040 - 2500 RPM
-ELP. 4500 W	40 – 48 VOLT	2750 – 3300 RPM
-ELP. 5000 W	24 VOLT	2150 RPM
-ELP. 5500 W	48 VOLT	3050 RPM

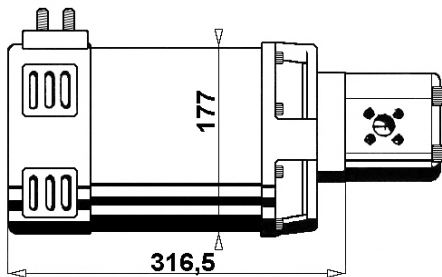

-ELP. 5500 W	48 VOLT	2130 RPM
-ELP. 6000 W	40 VOLT	1900 RPM
-ELP. 6000 W	48 VOLT	2300 RPM
-ELP. 6000 W	72 VOLT	1700 RPM
-ELP. 6000 W	80 VOLT	1900 RPM

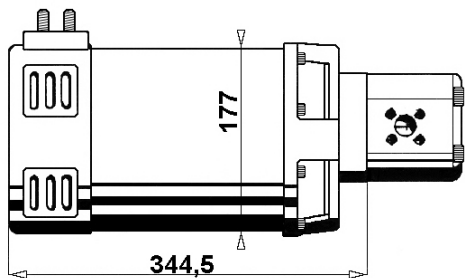

-ELP. 6000 W	40 VOLT	1900 RPM
-ELP. 6500 W	48 VOLT	2200 RPM
-ELP. 6500 W	80 VOLT	1750 RPM

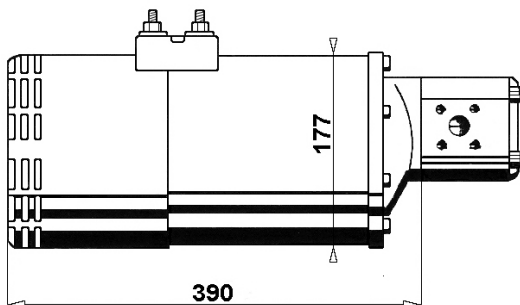

-ELP. 5000 W	48 VOLT	2270 – 3200 RPM
-ELP. 5000 W	40 VOLT	2100 RPM
-ELP. 5000 W	80 VOLT	2000 – 3100 RPM
-ELP. 5000 W	80 VOLT	2160 RPM

D.C. OIL HIDRAULIC ELECTROPUMPS

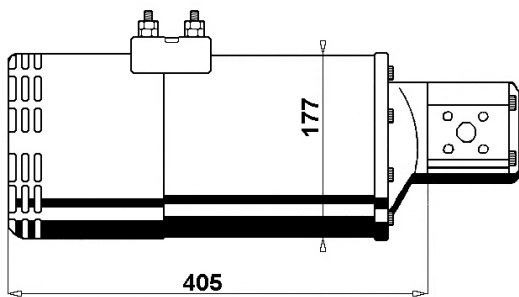

- ELP. 8000 W 48 VOLT 2000 – 2500 RPM
- ELP. 8000 W 40 VOLT 2000 RPM
- ELP. 8000 W 72 VOLT 1500 RPM
- ELP. 8000 W 80 VOLT 1700 – 2380 RPM

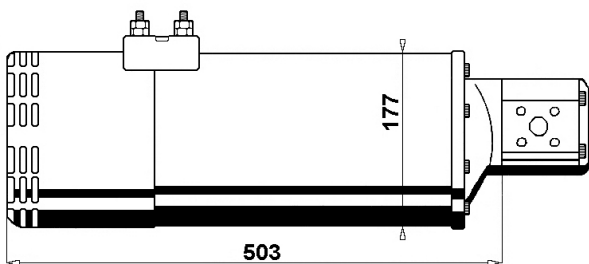

- ELP. 8000 W 48 VOLT 1150 – 1750 RPM
- ELP. 8000 W 48 VOLT 2000 RPM
- ELP. 10000 W 48 VOLT 2000 RPM
- ELP. 10000 W 80 VOLT 2000 RPM

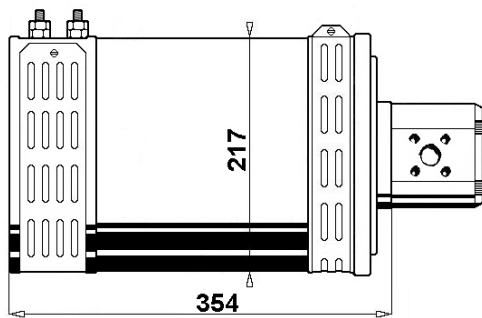

- ELP. 5 KW 24 VOLT 1200 RPM
- ELP. 7 KW 36 VOLT 2000 RPM
- ELP. 8 KW 40 VOLT 1700 RPM
- ELP. 8 KW 48 VOLT 2260 RPM
- ELP. 8 KW 48 VOLT 1700 – 2460 RPM
- ELP. 9 KW 48 VOLT 2300 RPM
- ELP. 10 KW 80 VOLT 2400 RPM

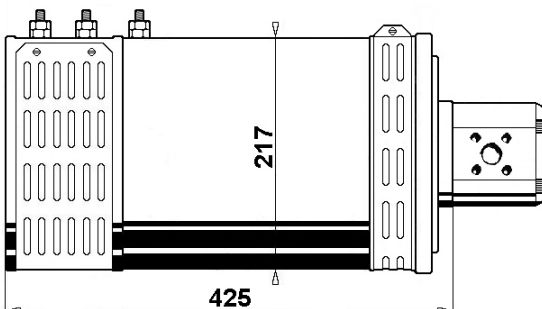

- ELP. 8 KW 40 VOLT 1500 RPM
- ELP. 8 KW 48 VOLT 1800 RPM
- ELP. 10 KW 48 VOLT 1600 RPM
- ELP. 10 KW 72 VOLT 1800 RPM
- ELP. 10 KW 80 VOLT 2000 RPM
- ELP. 12 KW 72 VOLT 1800 RPM
- ELP. 16 KW 80 VOLT 2300 RPM

D.C. OIL HIDRAULIC ELECTROPUMPS

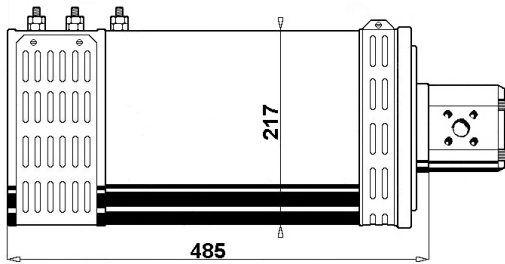

-ELP. 16,8 KW 80 VOLT 1800 RPM

-ELP. 17 KW 80 VOLT 1800 RPM

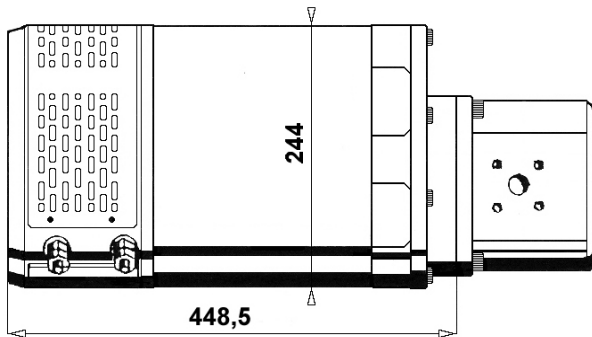

-ELP. 10 KW 48 VOLT 1000 RPM

-ELP. 10 KW 48 VOLT 1030 – 1300 RPM

-ELP. 10 KW 72 VOLT 1470 RPM

-ELP. 10 KW 80 VOLT 1700 RPM

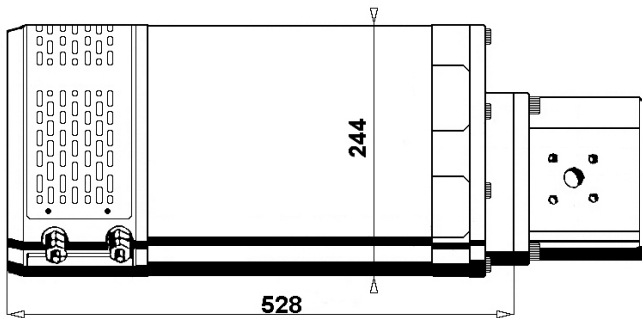

-ELP. 14 KW 80 VOLT 1300 RPM

-ELP. 14 KW 72 VOLT 1170 RPM

-ELP. 14 KW 80 VOLT 1080 – 1290 RPM

-ELP. 14 KW 72 VOLT 970 – 1160 RPM

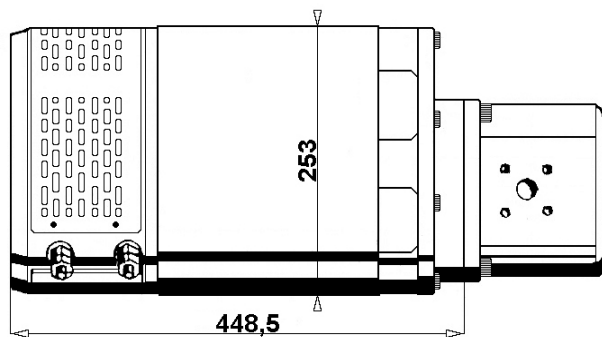

-ELP. 16,8 KW 80 VOLT 1450 RPM

-ELP. 15,5 KW 72 VOLT 1350 RPM

-ELP. 10 KW 48 VOLT 1200 RPM

D.C. OIL HIDRAULIC ELECTROPUMPS

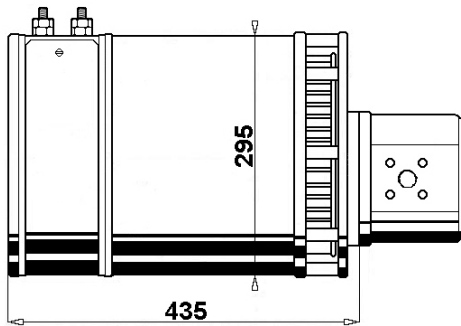

- ELP. 20 KW 80 VOLT 1400 RPM
- ELP. 18 KW 80 VOLT 1500 RPM
- ELP. 18 KW 72 VOLT 1400 RPM
- ELP. 15 KW 80 VOLT 1400 RPM

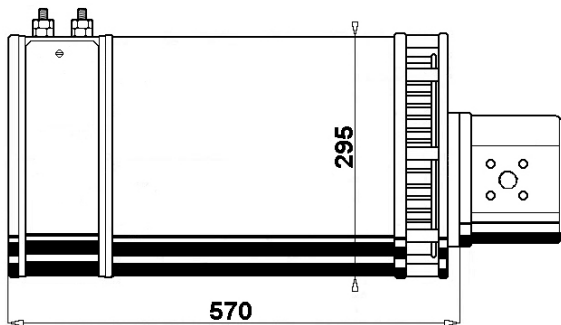

- ELP. 20 KW 72 VOLT 1000 RPM
- ELP. 22 KW 80 VOLT 1850 RPM
- ELP. 25 KW 80 VOLT 1700 RPM

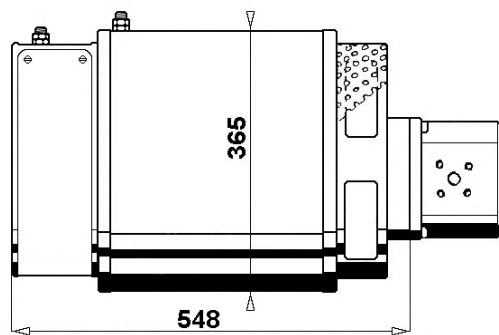

- ELP. 20 KW 72 VOLT 1150 RPM
- ELP. 20 KW 80 VOLT 1250 RPM
- ELP. 22 KW 72 VOLT 1000 RPM
- ELP. 22 KW 80 VOLT 1100 RPM

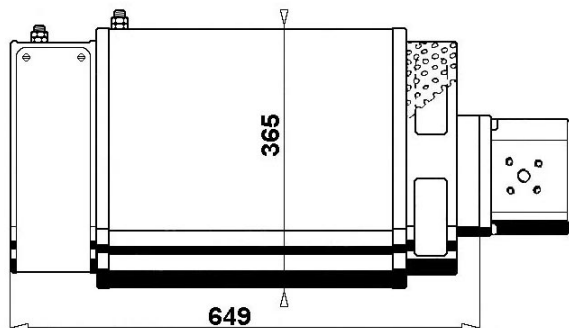

- ELP. 27 KW 72 VOLT 1200 RPM
- ELP. 30 KW 80 VOLT 1150 RPM
- ELP. 35 KW 80 VOLT 1100 RPM

ELECTROPUMPS FOR STEERING

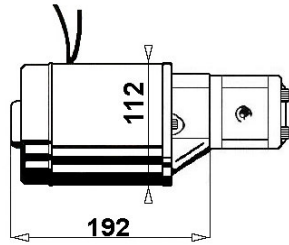

- ELP. STEERING 500 W 12 VOLT 2000 RPM
- ELP. STEERING 500 W 24 VOLT 2000 RPM
- ELP. STEERING 500 W 40-48 VOLT 2000 RPM

PERMANENT MAGNETS

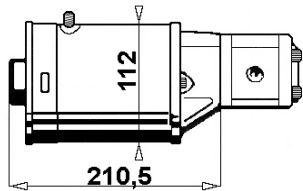

- ELP. STEERING 500 W 24 VOLT 2250 RPM
- ELP. STEERING 500 W 36 VOLT 2580 RPM

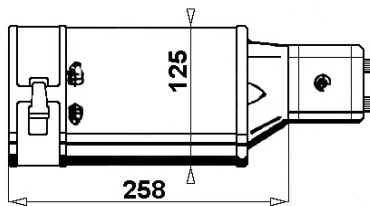

- ELP. STEERING 500 W 24 VOLT 1670 RPM
- ELP. STEERING 700 W 36 VOLT 2250 RPM
- ELP. STEERING 1000 W 48 VOLT 2800 RPM
- ELP. STEERING 1000 W 80 VOLT 2250 RPM

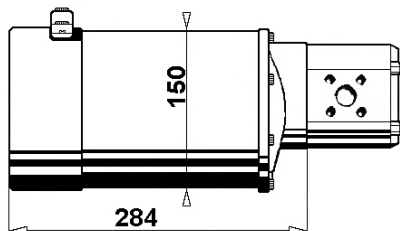

- ELP. STEERING 1000 W 24 VOLT 1500 RPM
- ELP. STEERING 1000 W 36 VOLT 1400 RPM
- ELP. STEERING 1000 W 48 VOLT 1180 RPM
- ELP. STEERING 1000 W 80 VOLT 1500 RPM

ELECTROPUMPS FOR STEERING

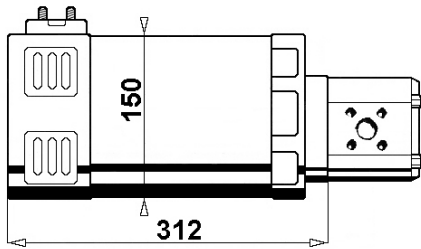

- ELP. STEERING 1200 W 24 VOLT 1500 RPM
- ELP. STEERING 1200 W 36 VOLT 1400 RPM
- ELP. STEERING 1200 W 48 VOLT 1180 RPM
- ELP. STEERING 1200 W 48 VOLT 1900 RPM

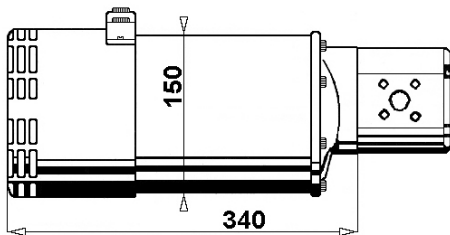

- ELP. STEERING 1200 W 24 VOLT 1500 RPM
- ELP. STEERING 1200 W 36 VOLT 1400 RPM
- ELP. STEERING 1200 W 48 VOLT 1180 RPM
- ELP. STEERING 1200 W 80 VOLT 1900 RPM

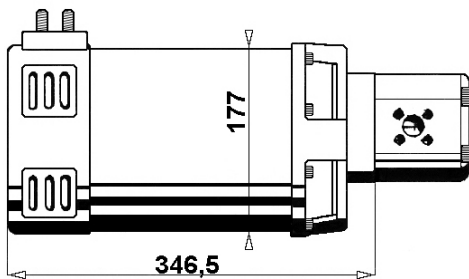

- ELP. STEERING 2000 W 48 VOLT 1200 RPM
- ELP. STEERING 2000 W 80 VOLT 1600 RPM

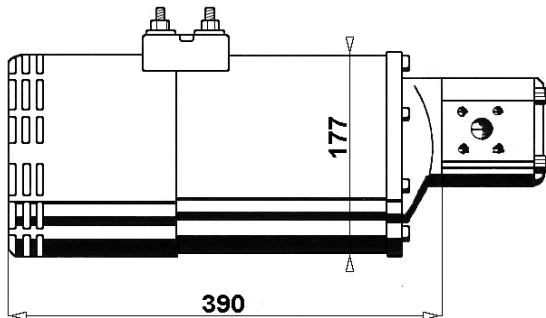

- ELP. STEERING 2000 W 48 VOLT 1200 RPM
- ELP. STEERING 2000 W 80 VOLT 1600 RPM

AMRE

MOTOR INSULATION CLASSES

To prevent current dispersion between lead-lead and lead-earth, insulating materials will have to be placed between all the electrical components of the motor.

Regulations split insulating materials into insulation classes according to the capacity these have of maintaining their insulating characteristics when operating temperatures increase. Classification is made according to maximum acceptable running temperatures for the specific materials.

Operating limit temperature is indicated as maximum overheating with respect to the ambient temperature considering a safety margin of 15°C. The ambient temperature, and therefore also the temperature of any cooling fluid, is conventionally considered as a maximum 40°C.

Electric motors are usually insulated in the following classes: E, B, F, H; of these, the highest is "H" with maximum acceptable insulation temperature of 180°C (40+125+15). This class provides motors with longer service times and durability, operating conditions being equal.

All A.M.R.E motors are class H.

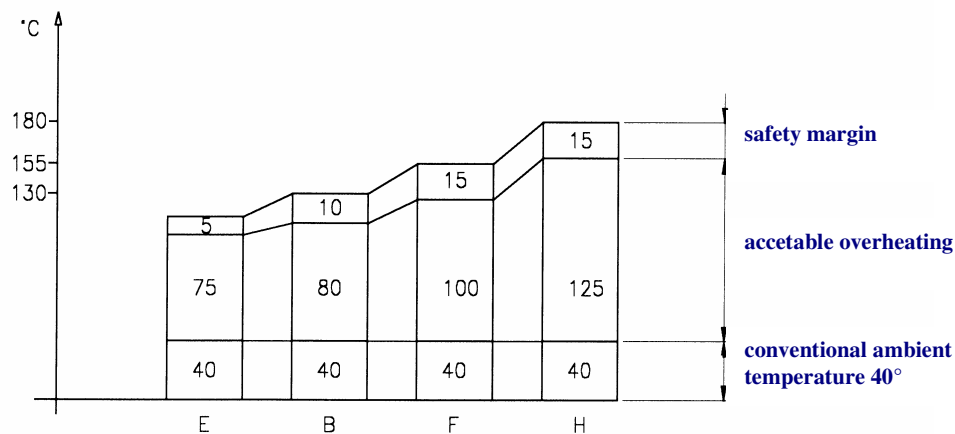

Fig. 1: diagram of maximum acceptable temperatures

Important: the temperatures shown in Fig. 1 relate to insulating materials only. Applicable regulations (CEI 2-3 file 355 and subsequent updates) prescribe maximum operating temperatures for electric motor windings below those shown in the illustration.

MOTOR TEST DIAGRAMS

AMRE has a modern electronic test bench for electric motors capable of evaluating the performance of motors with powers between 200W and 50kW and torques from 0.1 to 50 Kgm. On request, each motor is equipped with a graph showing the characteristic curves obtained in compliance with applicable Italian and European standards. The following, in particular, are shown:

Power curve	UDM	kW	Absorption curve	UDM	Amp
Velocity curve	UDM	rpm	Performance curve	UDM	%
Drive torque curve	UDM	Kgm	Service time curve S2	UDM	min
Service time curve S3	UDM	%	Voltage curve	UDM	Volt

The service time curves S2, S3 are determined in conformity with table No.1 file 1778 V C.E.I. standards 2-3 v1 ED. 1992.

Please also remember that such service times refer to our test bench at an altitude below 1000 metres and at average European temperature.

The graphs below provide details of the S1, S2 and S3 service time concepts normally used for **AMRE** motors.

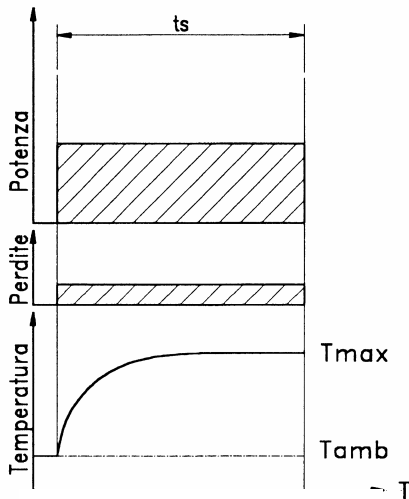

Continuous Service S1

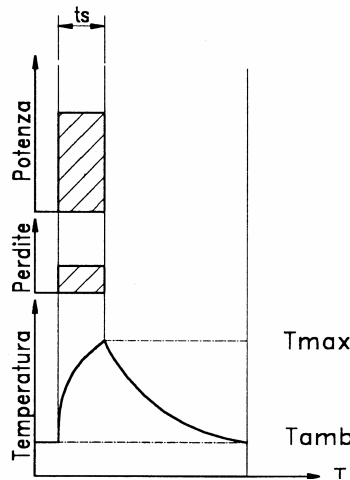

Limited duration Service S2

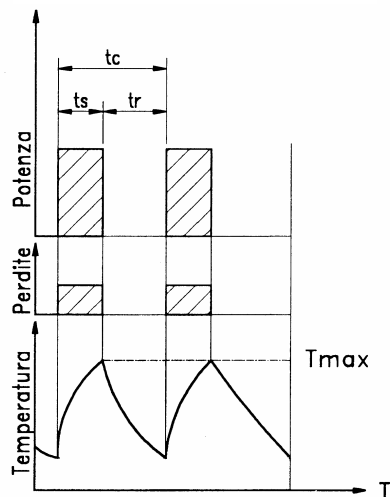

Periodical Intermittent Service S3

$$S3 = \frac{t_s}{t_s + t_r} * 100$$

- Tc** Duration of a cycle (10 minutes)
- Ts** Operating time and constant power
- Tr** Quiescent time
- Tmax** Max temperature reached
- Tamb** Ambient temperature



INSULATION STANDARDS

The insulation standard of a motor indicates the level of protection of the motor against solid bodies and water. It is indicated by two decimal figures:

1st CHARACTERISTIC FIGURE

The first characteristic figure indicates the insulation standard of the casing with respect to both persons and materials.

- 0 not insulated
- 1 insulated against solid bodies over 50 mm in size
- 2 insulated against solid bodies over 12 mm in size
- 3 insulated against solid bodies over 2.5 mm in size
- 4 insulated against solid bodies over 1 mm in size
- 5 insulated against dust
- 6 totally insulated against dust

2nd CHARACTERISTIC FIGURE

The second characteristic figure indicates the insulation standard of the casing against the penetration of water (see illustrations on next page).

- 0 not insulated
- 1 insulated against the vertical fall of water drops
- 2 insulated against the fall of water drops with a max gradient of 15°
- 3 insulated against rain
- 4 insulated against spray
- 5 insulated against jets of water
- 6 insulated against waves
- 7 insulated against the effects of immersion
- 8 insulated against the effects of submersion

Important: the figures indicated are simply a summary of those shown in the “CEI 2-16” regulation on insulation standard. Please refer to this for more detailed information.

MOTORS OPERATING IN SEVERE ENVIRONMENTAL CONDITIONS

The rated motor figures on the technical sheets refer to operation in climates with max. environmental temperatures of 40°C at altitudes up to 1000 metres. In the case of higher environmental temperatures and altitudes, rated powers must be reduced by a coefficient K obtained from the table below.

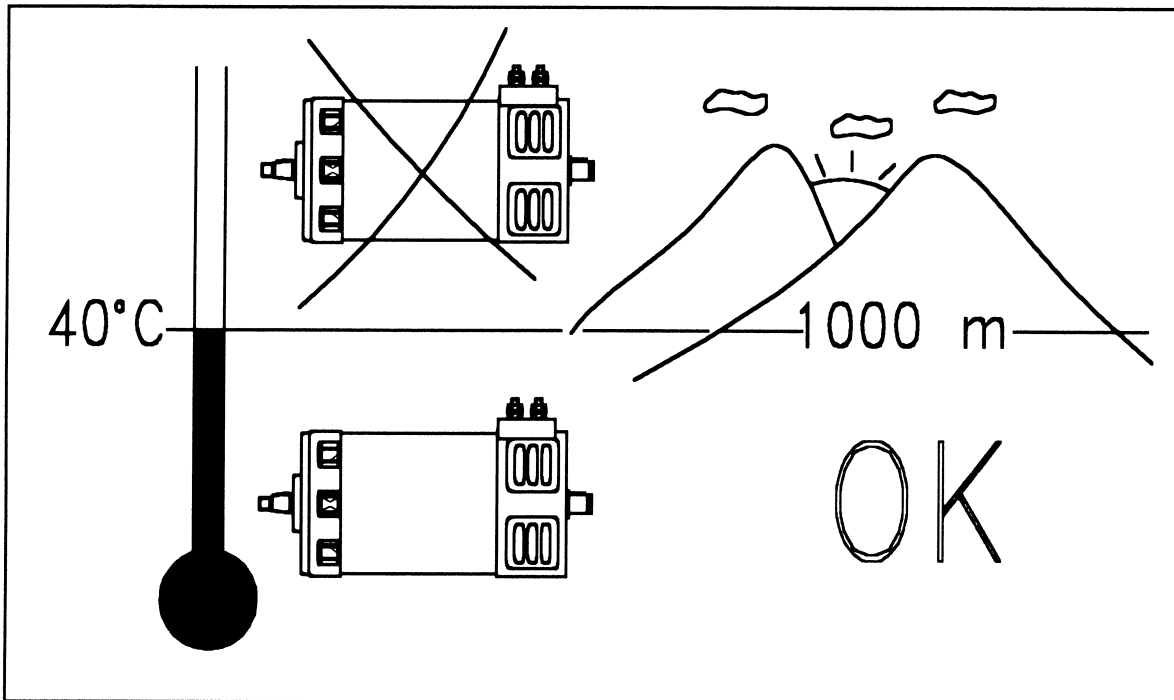

DEGREES	K	ALTITUDE	K
45	0.95	1500	0.95
50	0.90	2000	0.90
55	0.80	3000	0.80
60	0.70	4000	0.70

AMRE

GEAR PUMPS

AMRE motor-driven pumps feature gear pumps in groups 1, 2 or 3 depending on motor category.

Below are the technical and mechanical specifications of the various pumps used besides a series of indications for correct installation in the hydraulic circuit.

PUMP GROUP 1

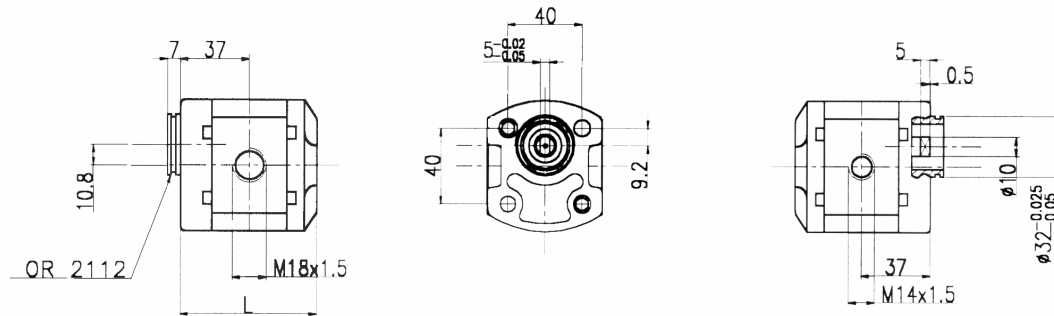

DISPLACEMENT cm ³ /rev	AMRE CODE	Bar Pressure Bar Max Pressures			SPEED rpm	
		P1	P2	P0	MIN	MAX
1.1	A1	210	250	-	600	6000
2.1	C	210	250	-	600	6000
3.2	D	200	240	-	600	5000

PUMP GROUP 2

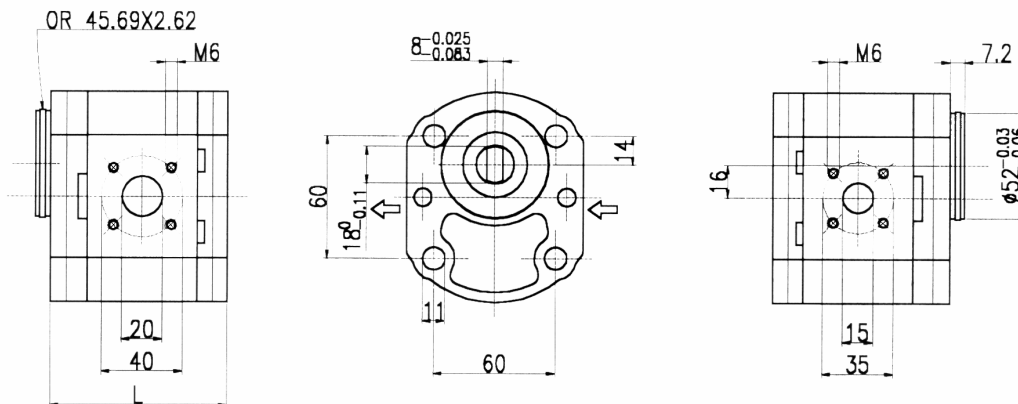

DISPLACEMENT cm ³ /rev	AMRE CODE	Bar Pressure Bar Max Pressures			SPEED rpm	
		P1	P2	P0	MIN	MAX
4	E	250	280	-	800	4000
6	F	250	280	-	800	4000
8	G	250	280	-	800	4000
11	H	250	280	-	800	4000
14	S	250	280	-	800	4000
17	I	250	280	-	800	4000
19	O	210	230	-	800	4000
25	M2	160	200	-	800	4000

PUMP GROUP 3

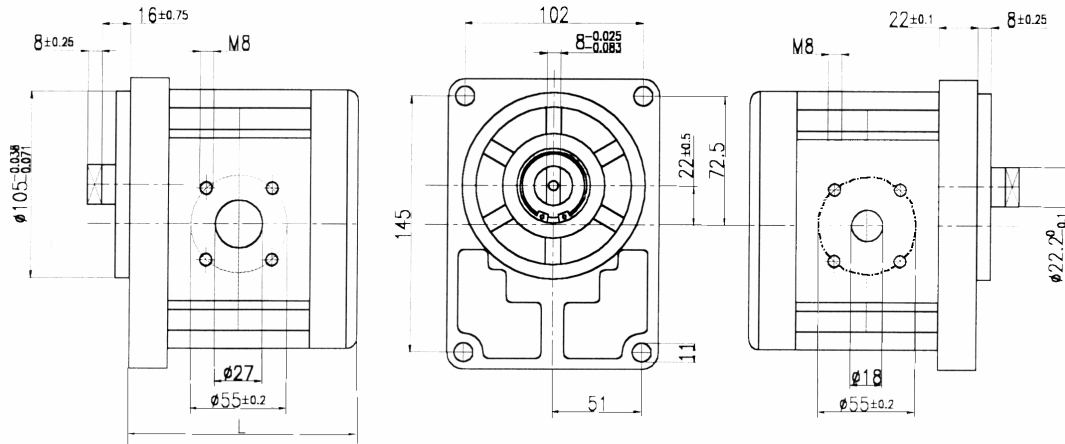

DISPLACEMENT cm ³ /rev	AMRE CODE	Bar Pressure Bar Max Pressures			SPEED rpm	
		P1	P2	P0	MIN	MAX
22	L	180	220	-	800	2500
26	M	180	220	-	800	2500
33	N	180	220	-	800	2500
38	P	150	180	-	800	2500
44	R	150	180	-	800	2500

