

THERMAL OVERLOAD RELAYS



Thermal overload relays	101
Technical data	104
Dimension drawings	106

Thermal overload relays



Thermal overload relays

Application:

Thermal overload relays TM and TRM are designed to protect low voltage motors and other consumers against nonpermissible overloads and phase-failure operations.

Advantages:

- In conformity with: IEC 60947-1, IEC 60947-4-1
- Ambient temperature compensated
- Differential tripping
- Selective manual or auto reset
- Trip indication
- Auxiliary contacts (1NO + 1NC)
- Small mounting dimensions and overall size



Ordering:

TM 40	16A
1	2

1 - Type

2 - Overload setting range (Upper value)

Thermal overload relays - direct mounting on the contactor

Thermal overload relay TM 40

Type	Order number	Overload setting range (A)	Usage	Weight [g]	Packing [pcs]
TM 40 - 0.16A	680001	0.1 - 0.16	CNN 9 CNN 12 CNN 18 CNN 22 CNN 25 CNN 30 CNN 32 CNN 40	115	1
TM 40 - 0.25A	680002	0.16 - 0.25			
TM 40 - 0.4A	680003	0.25 - 0.4			
TM 40 - 0.63A	680004	0.45 - 0.63			
TM 40 - 0.8A	680005	0.55 - 0.8			
TM 40 - 1A	680006	0.75 - 1			
TM 40 - 1.3A	680007	0.9 - 1.3			
TM 40 - 1.6A	680008	1.1 - 1.6			
TM 40 - 2.0A	680009	1.4 - 2.0			
TM 40 - 2.5A	680010	1.8 - 2.5			
TM 40 - 3.2A	680011	2.3 - 3.2			
TM 40 - 4.0A	680012	2.9 - 4.0			
TM 40 - 4.8A	680013	3.5 - 4.8			
TM 40 - 6.3A	680014	4.5 - 6.3			
TM 40 - 7.5A	680015	5.5 - 7.5			
TM 40 - 10A	680016	7.2 - 10			
TM 40 - 12.5A	680017	9 - 12.5			
TM 40 - 16A	680018	11.3 - 16			
TM 40 - 20A	680019	15 - 20			
TM 40 - 25A	680020	21 - 25*			
TM 40 - 30A	680021	24.5 - 30*			
TM 40 - 36A	680022	29 - 36*			
TM 40 - 38A	680023	33 - 38*			
				145	

*with additional screw terminals



Thermal overload relay TRM 75 - N60

Type	Order number	Overload setting range (A)	Usage	Weight [g]	Packing [pcs]
TRM 75 N60 - 25A	605732	16 - 25	CNN 50 CNN 60 CNN 70	390	1
TRM 75 N60 - 32A	605726	20 - 32			
TRM 75 N60 - 40A	605274	25 - 40			
TRM 75 N60 - 50A	604944	32 - 50			
TRM 75 N60 - 57A	604945	40 - 57			
TRM 75 N60 - 63A	604946	50 - 63			
TRM 75 N60 - 70A	607729	57 - 70			



Thermal overload relay TRM 75 - N90

Type	Order number	Overload setting range (A)	Usage	Weight [g]	Packing [pcs]
TRM 75 N90 - 25A	605733	16 - 25	CNN 80 CNN 90 CNN 100	400	1
TRM 75 N90 - 32A	605734	20 - 32			
TRM 75 N90 - 40A	605735	25 - 40			
TRM 75 N90 - 50A	605736	32 - 50			
TRM 75 N90 - 57A	605737	40 - 57			
TRM 75 N90 - 63A	605691	50 - 63			
TRM 75 N90 - 70A	605692	57 - 70			
TRM 75 N90 - 80A	605530	63 - 80			



Thermal overload relays - direct mounting on the contactor



Thermal overload relay TRM 75 - 110

Type	Order number	Overload setting range (A)	Usage	Weight [g]	Packing [pcs]
TRM 75 110 - 25A	739159	16 - 25	CNM 110	400	1
TRM 75 110 - 32A	739171	20 - 32			
TRM 75 110 - 40A	739172	25 - 40			
TRM 75 110 - 50A	739173	32 - 50			
TRM 75 110 - 57A	739174	40 - 57			
TRM 75 110 - 63A	739160	50 - 63			
TRM 75 110 - 70A	739176	57 - 70			
TRM 75-110 - 80A	739195	63 - 80			

Thermal overload relays - individual mounting



Thermal overload relay TRM 400D*

Type	Order number	Overload setting range (A)	Usage	Weight [kg]	Packing [pcs]
TRM 400D - 100A	680051	70 - 100	CNM 110	1.58	1
TRM 400D - 130A	680052	90 - 130	CNM 140		
TRM 400D - 160A	680053	110 - 160	CNM 170		
TRM 400D - 200A	680054	140 - 200	CNM 200		
TRM 400D - 250A	680055	180 - 250	CNM 250		
			CNM 315		
			CNM 400		

*TRM400D with straight-through transformer



Thermal overload relay TRM 400

Type	Order number	Overload setting range (A)	Usage	Weight [kg]	Packing [pcs]
TRM 400 - 100A	680044	70 - 100	CNM 110 CNM 140 CNM 170 CNM 200 CNM 250 CNM 315 CNM 400	2.2	1
TRM 400 - 130A	680045	90 - 130			
TRM 400 - 160A	680046	110 - 160			
TRM 400 - 200A	680047	140 - 200			
TRM 400 - 250A	680048	180 - 250			
TRM 400 - 320A	680049	230 - 320			
TRM 400 - 400A	680050	280 - 400			

Separate mounting adapter for TM 40 and TRM 75

Adapter ASM 40

Type	Order number	Usage	Weight [g]	Packing [pcs]
ASM 40	680043	TM 40	57	1

Adapter ASM 75

Type	Order number	Usage	Weight [g]	Packing [pcs]
ASM 75	600009	TRM 75	135	1



Technical data

Relay type		TM 40	TRM 75	TRM 400/TRM 400D
Insulation rating U _i	V	690	1000	690
Rated impulse withstand voltage U _{imp}	kV	6		
Permissible ambient temperature	°C	- 5 to +50		
Degree of protection		IP20	IP00	
Class		10A	10	10A
Temperature compensation		+	+	+
Phase failure protection by differential phase shift		+	+	+
Test button		+	+	+
Reset button		+	+	+
Switch position indicator		+	+	+
Changeover to hand or automatic resetting		+	+	+
Vibration resistance	g	8	8	8
Overvoltage category and pollution degree acc.to IEC/EN60947-1		III/3		
Main circuit conductor cross - section solid or stranded finely stranded with end sleeve Screw/Screw head Tightening torque	mm ² mm ² Nm	1 - 6 (10*) 1,5 - 6 (10*) M4 (M5*) 1.2 (2*)	2,5 - 35 1,5 - 25 M6 2.5	240/120 M10/-
Power input per pole max. at setting range min. max. at setting range max.	W/VA W/VA	0,9 2,25	2,6 4	5 12
Auxiliary circuit number and type of contacts conductor cross - section solid or stranded finely stranded with end sleeve Screw/Screw head Tightening torque Thermal current (both contacts) I _{th} ; 35 °C	mm ² mm ² Nm A	1 NO + 1 NC (galvanically separated) 2 x (1 - 2,5) 2 x (0,75 - 1,5) M3.5/PZ2 0.8 6		
Rated operational currents (both contacts) AC-15 240V 400V 500V	le A	3 1.7 1	1.15 1.1 1	3 1.7 1
Rated operational currents (both contacts) DC-13 110V 230V	le A	0.25 0.10	0.22 0.10	0.25 0.10

*for additional screw terminals up to 10mm²

Tripping curves of thermal overload relays

TM 40 - Current range 0.1 - 38A

Three-phase protection characteristics

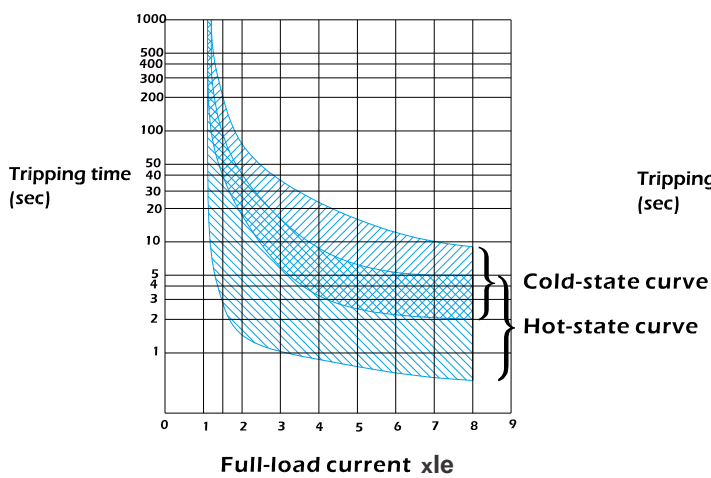

TRM 400 - Current range 70 - 400A

Three-phase protection characteristics

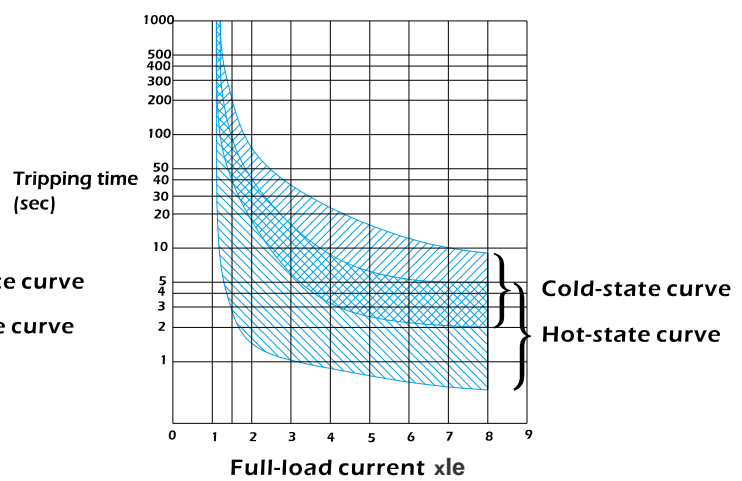

TRM 75 - Current range 16 - 80A

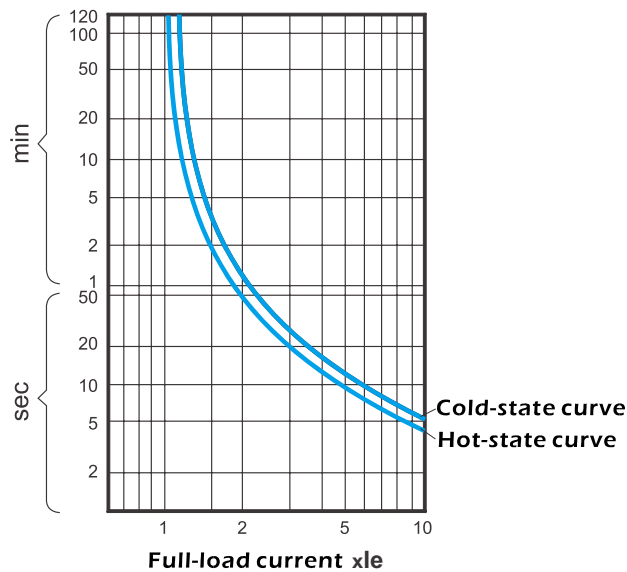

Dimension drawings (mm)

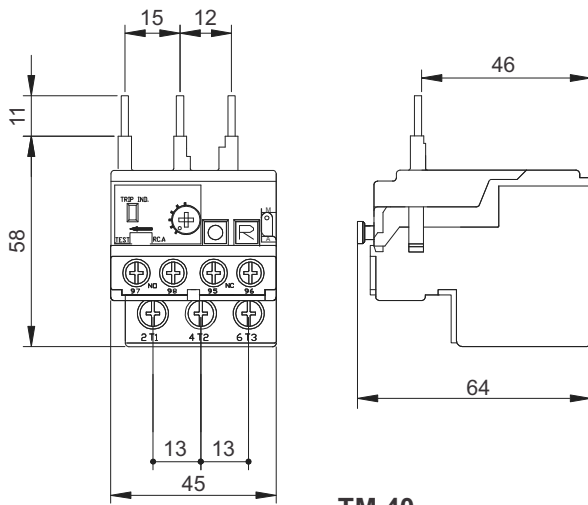

TM 40

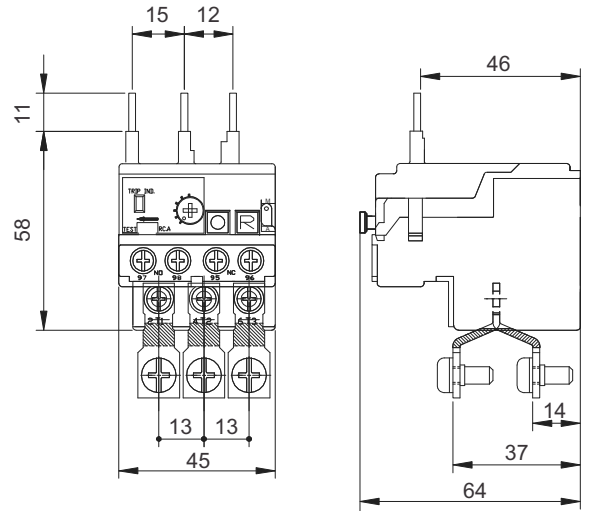

TM 40 with additional terminals

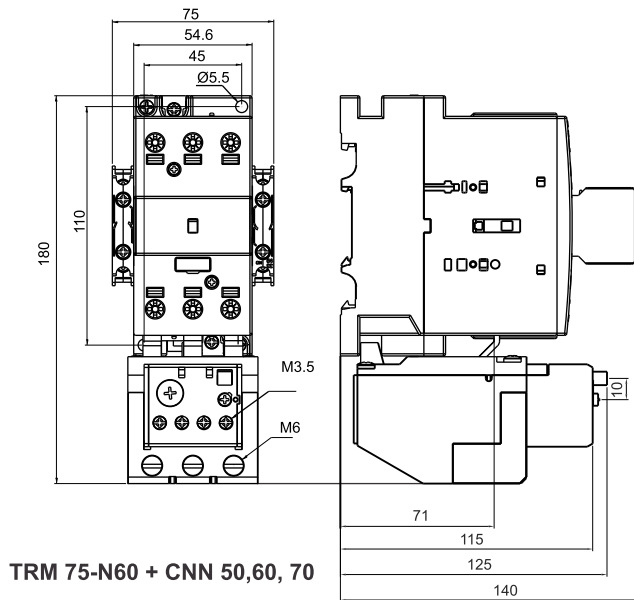

TRM 75-N60 + CNN 50,60,70

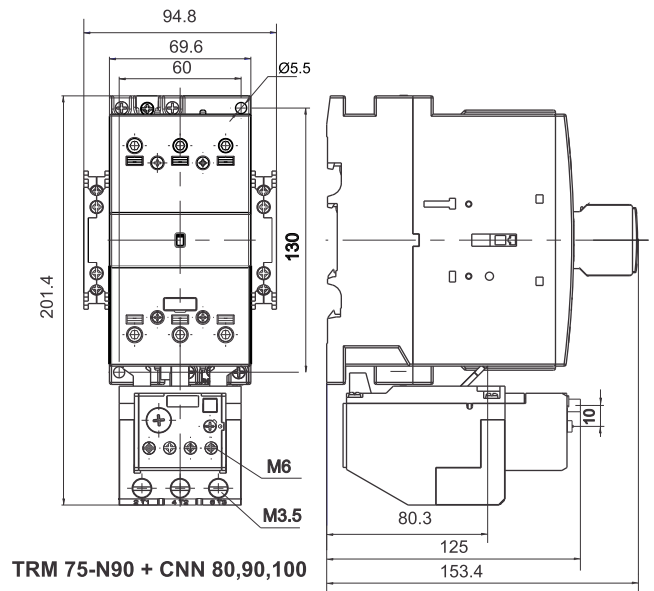

TRM 75-N90 + CNN 80,90,100

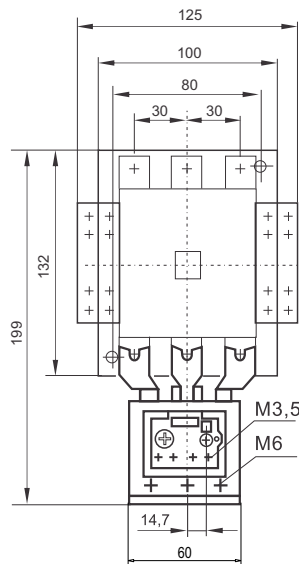

TRM 75-110 + CNM 110

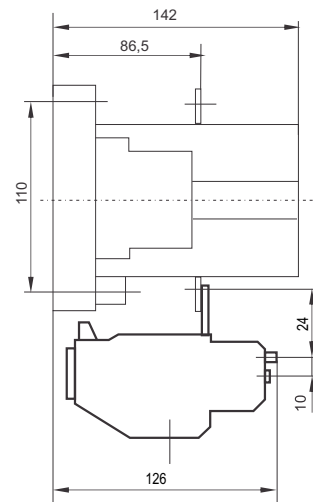

TRM 400

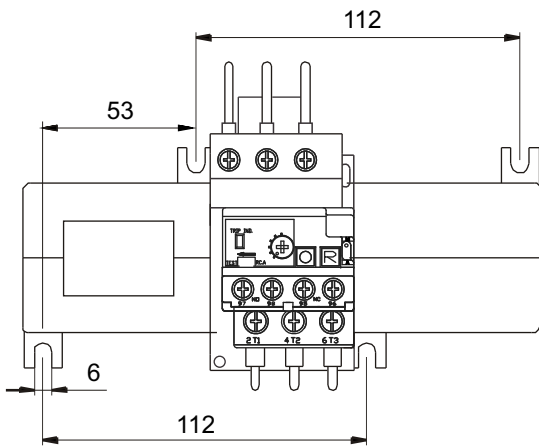
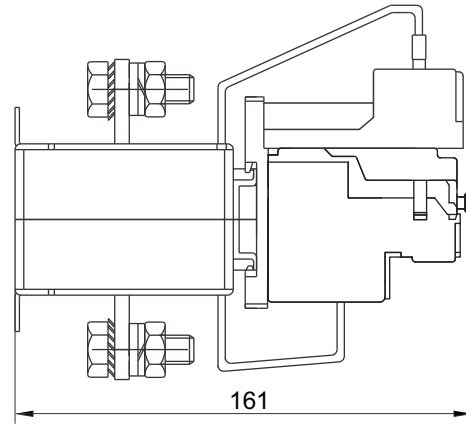
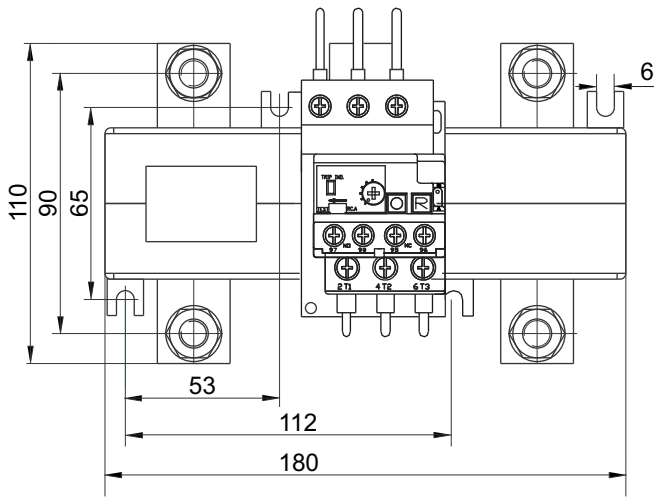

TRM 400D

