

WATER PROOF SWITCHES

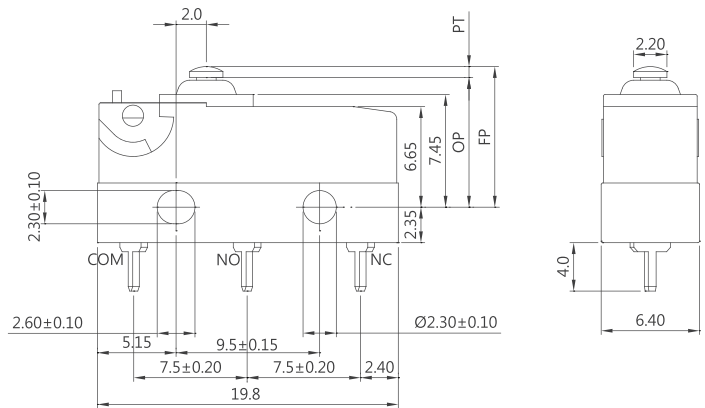

DIMENSIONS

Unless otherwise specified, a tolerance of $\pm 0.4\text{mm}$ applies to all dimensions.



SW SERIES

SPECIFICATIONS

Contact Resistance(initial)

Max. 30 m Ω

Measured by ohm meter - open voltage <1VDC, driver current -100 mA

Insulation Resistance (at 500 VDC / minute)

Min. 100 M Ω

Dielectric Strength

Min. 1000VAC(50-60HZ)/minute between Live parts.

Min. 1500VAC(50-60HZ)/minute between Live parts and dead metal parts

Operating Temperature Range

-40°C to 120°C (with no icing)

Vibration

10~55Hz, displacement 0.75 mm (p-p)

Electrical Service Life

Min. 10,000 operations

Electrical Operating Frequency

10~30 operations per minute

Mechanical Service Life

Min. 2,000,000 operations

Mechanical Operating Frequency

120 operations per minute

Operating application of the switch

Set the switch pushing distance from 60% to 90% of the specified OT value

APPLICATIONS

Telephone, Air Conditioner, Computer, Humidifier, Alarm, Time Recorder, Mixer & Chopper, Solder Gun, Neon Phone, Fax Machine, Joystick, Water Pump, Gas Detector, Pencil Sharpener, Money Sorter, Food Processor, Electric Knife, Toy Car, Juice Maker, Electric Steak Pan

CONTACT CONFIGURATION

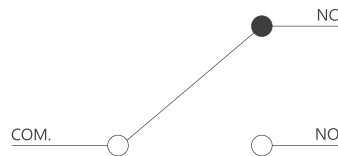

MOUNTING HOLES

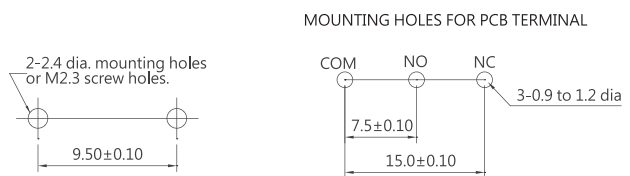

CERTIFICATE INFORMATION

| Model Name | UL, cUL | ENEC |
|------------|---|--------------------------|
| SW-05 | 0.1A 125/250VAC 5A 125/250VAC (Temp: 120°C) Min. 6000 operations | 6A 250VAC μ T120 1E4 |

WATER PROOF SWITCHES

TERMINAL TYPES

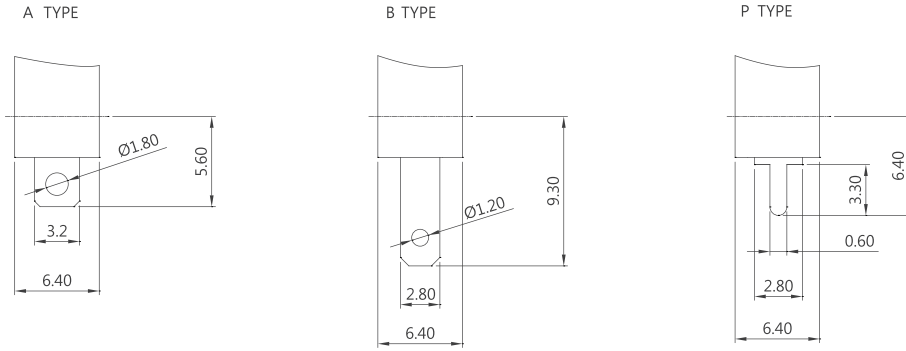

ORDERING INFORMATION

| | | | | | | | | | | | | | |
|----------------------|-------------|----------------------------------|----------|-------------|------------------------|----------|-------------|----------------------|-------------|----------------------------|---|------------------|--|
| S | W | 0 | 5 | S | 0 | 0 | A | 0 | Z | | | | |
| SERIES PREFIX | CODE | RATING CURRENT | | CODE | OPERATING FORCE | | CODE | TERMINAL TYPE | CODE | CIRCUIT ARRANGEMENT | | ROHS CODE | |
| | 05 | 5A 125/250 VAC 6A 125/250 VAC | | S | STANDARD | | | | 0 | S.P.D.T | | | |
| | | | | | | | 00 | | A | | 1 | S.P.S.T NO | |
| | | | | | | | 01 | | | | 2 | S.P.S.T NC | |
| | | | | | | | 02 | | B | | | | |
| | | | | | | | 03 | | | | | | |
| | | | | | | | 04 | | P | | | | |
| | | | | | | | 05 | | | | | | |
| | | | | | | | 06 | | | | | | |
| | | | | | | | 07 | | | | | | |
| | | | | | | | 08 | | | | | | |
| | | | | | | | 09 | | | | | | |

OPERATING CHARACTERISTICS

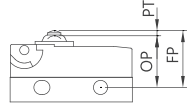
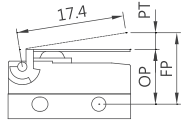
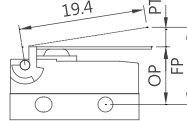
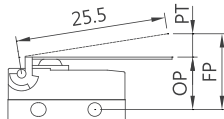
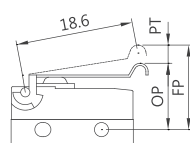
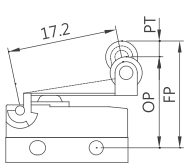
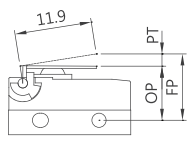
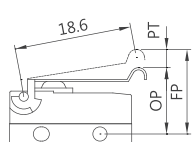
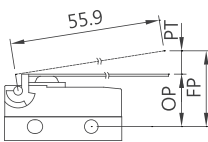
| SWITCH TYPE | PART SUFFIX | OF Max. (gf) | OP (mm) | PT Max. (mm) | OT Min. (mm) | MD Max. (mm) | FP Max. (mm) | RF Min. (gf) |
|-----------------|---|--------------|----------|--------------|--------------|--------------|--------------|--------------|
| SW-05S-00 □□ -Z |  | 203 | 8.4±0.3 | 1.2 | 0.6 | 0.2 | 9.9 | 50 |
| SW-05S-01 □□ -Z |  | 82 | 8.8±1.1 | 4.3 | 0.9 | 0.6 | 12.0 | 16 |
| SW-05S-02 □□ -Z |  | 66 | 8.8±1.2 | 4.8 | 1.0 | 0.7 | 12.4 | 13 |
| SW-05S-03 □□ -Z |  | 54 | 8.8±1.6 | 6.3 | 1.6 | 0.9 | 13.5 | 11 |
| SW-05S-04 □□ -Z |  | 68 | 10.7±1.2 | 4.6 | 1.0 | 0.65 | 14.1 | 14 |
| SW-05S-05 □□ -Z |  | 72 | 14.5±1.1 | 4.3 | 0.9 | 0.6 | 17.7 | 15 |
| SW-05S-06 □□ -Z |  | 98 | 8.8±0.9 | 3.2 | 0.6 | 0.5 | 11.1 | 21 |
| SW-05S-07 □□ -Z |  | 39 | 8.8±2.6 | 10.1 | 2.1 | 2.3 | 16.3 | 8 |
| SW-05S-08 □□ -Z |  | 68 | 11.3±1.3 | 4.9 | 0.95 | 0.8 | 14.9 | 13 |
| SW-05S-09 □□ -Z |  | 33 | 8.8±3.5 | 13.8 | 2.9 | 3.6 | 19.1 | 7 |

CAUTIONS:
注意事項

1. To secure the switch, please use an M2.3 small screw on a flat surface and tighten with plane washers or spring washers to securely mount the switch, using a maximum torque of 0.16 N•m.
若使用定位孔型式，請使用M2.3小型螺絲固定在平面上，並使用平墊圈或者彈性墊圈以便安全的鎖固開關，鎖固扭力請勿超過0.16 N•m.
2. Do not handle the Switch in a way that may cause damage to the sealed rubber & switch sealing.
使用開關時，請勿損壞開關防水矽膠罩及開關防水膠。
3. To ensure the best performance of the switch, when handling/installing the switch, please do not apply uneven pressure to the direction indicated by the arrow in (Figure -1). Any uneven pressure or pressure direction other than the operating direction might be harmful or damage the switch performance.
為確保開關正常運作，安裝及取用開關時，請勿直接施加壓力在(圖-1)中箭所指示的方向。如圖所示，任何不對稱的壓力或作動方向以外的壓力都不適在開關按柄上。
4. Do not exceed the end position (EP) and over travel (OT). This could cause operation failure.
圖示設計按壓位置，請勿超過開關下死點及超出行程，以避免開關失效。
5. Avoid applying any grease/oil and chemicals on the switch rubber.
請避免沾附任何油脂或者化學物質在開關的矽膠防水罩上。

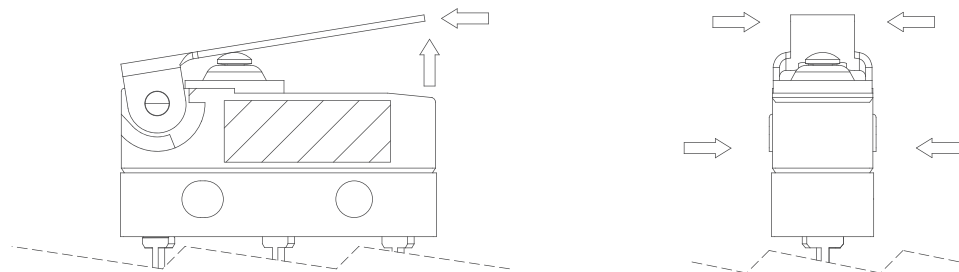

Figure-1